

MOBILE APP BASED STANDALONE ELECTRONIC DOOR LOCK

SoHo Elock Pro Fingerprint Smart Lock with Wi-Fi



FEATURES

Durable lock body with tempered glass surface finish designed to emphasize the aesthetic value

Multiple unlocking methods; fingerprint, PIN, RFID card and mechanical key independently

360 degree accurate identification with instant verification time of less than 1 sec

Supports IoT integration with home automation

Manage lock through SoHo by Vantage mobile application

Unlock remotely and check real-time unlock records via mobile application

Set permanent users PIN via mobile application and temporary PIN for visitors

Dynamic PIN for time bound access periodic users such as house-keeping staff

LED back lit touch keypad and voice prompt navigation

Interchangeable left or right lock handle alignment supported

Low battery alerts and external USB power terminal for emergency back up when battery is discharged

TECHNICAL SPECIFICATIONS

SoHo Elock Pro

Parameter	Specifications
Door Thickness	35-110mm
Mortise	60/68mm mortise
Fingerprint Sensor Type	Semiconductor biometric sensor
Resolution	500 DPI
Verification Time	≤ 0.5 sec
Wi-Fi	Supported
Power Supply	4 x 1.5V AA battery
Battery Backup	6-8 months
Static Power Consumption	≤ 150 mAh
Dynamic Power Consumption	≤ 45 mAh
Keypad	Touch Keypad
Lock Override	Mechanical key supported
Backup Unlocking	Emergency USB port
Finger Print Capacity	300 (9sets of administrators,291 users)
Password Capacity	300 (9sets of administrators,291 users)
Card Capacity	300 (9sets of administrators,291 users)
Working Temperature	-20°C ~ 30°C
Working Relative Humidity	20% ~ 93%
Material	Aluminum Alloy & tempered glass
Dimension	360L x 75W x 25H (mm)
Weight	800g (without battery)

*Exact products and specifications shown may vary by geographic region and are subject to change without notice. Weights and measurements are approximate and may vary.

Dimension:

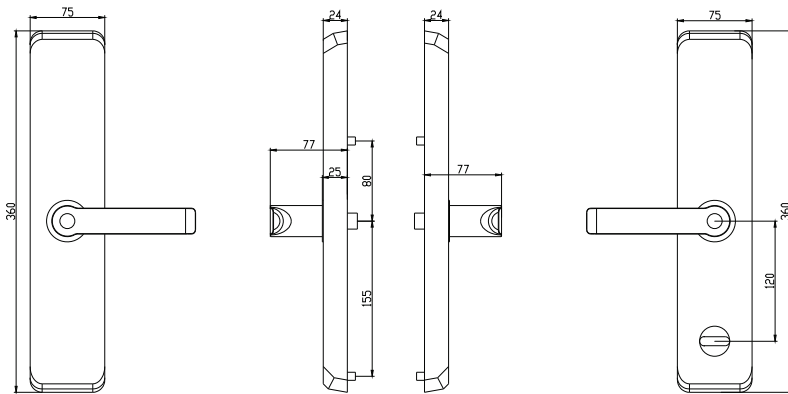

VANTAGE INTEGRATED SECURITY SOLUTIONS LIMITED.

B3, Bredon House 321, Tenttenhall Road Tettenhall, Wolverhampton
West Midlands, WV6 0JZ United Kingdom

Ph:+44-1902-793383, Email: sales@vantagesecurity.com

www.vantagesecurity.com

(AN ISO 9001 : 2008, ISO 14001:2004 CERTIFIED COMPANY)

