

# PEOPLE ENTRANCE MANAGEMENT SYSTEM

## V-PM4010-SGT3 SWING GATE BARRIER



### FEATURES

- Heavy-duty motorized-automatic swing gate
- Single/dual core bi-direction operating modes supported
- Half height operation with 800mm standard passage width
- LED status indicator & adjustable time out delay
- Automatic reset of barrier gate after each passage
- Integration support with any RFID/Biometric Reader through NO input
- Fail safe & fail lock function supported in case of emergency
- Top quality AISI 304 grade SS construction



LED Direction  
Indicators

INGRESS  
PROTECTION  
RATING

**IP44**



100%  
Duty Cycle



Delay Time



Wired  
Terminal

## TECHNICAL SPECIFICATIONS

# V-PM4010-SGT3

Parameter	Specifications
Passage Width	Standard 800mm; optional 900mm
Throughput Rate	35-40 persons per minute
Opening & Closing Speed	0.5 ~ 0.8s
Passing Time	5s default (adjustable 0-60s)
Drive	Electro-mechanical DC motor drive
Passage Direction	Unidirectional/ bidirectional
Power/Mechanism Failure	Fail safe or fail lock status for either one or both directions be in free movement mode (standard) or locks in the home position
Fire Alarm Integration	Supported to provide free passage for evacuation
Service Life	>5 million operation cycles
Communication Interface	Relay Input (NO/NC/COMM) Optional RS232/RS485
Operating Voltage	DC 24V
Power Supply Voltage	AC220~240 V
Max Power Consumption	50W
Working Temperature	-25°C~+70°C
Relative Humidity	≤90% no condensation
IP Rating	IP44
Chassis Material	Top quality AISI 304 grade stainless steel
Door Material	Acrylic
Dimension	440x200x1150mm
Net Weight	35kg single core
Certifications	CE, FCC, ROHS

\*Exact products and specifications shown may vary by geographic region and are subject to change without notice. Weights and measurements are approximate and may vary.

## DIMENSIONS

Unit: mm

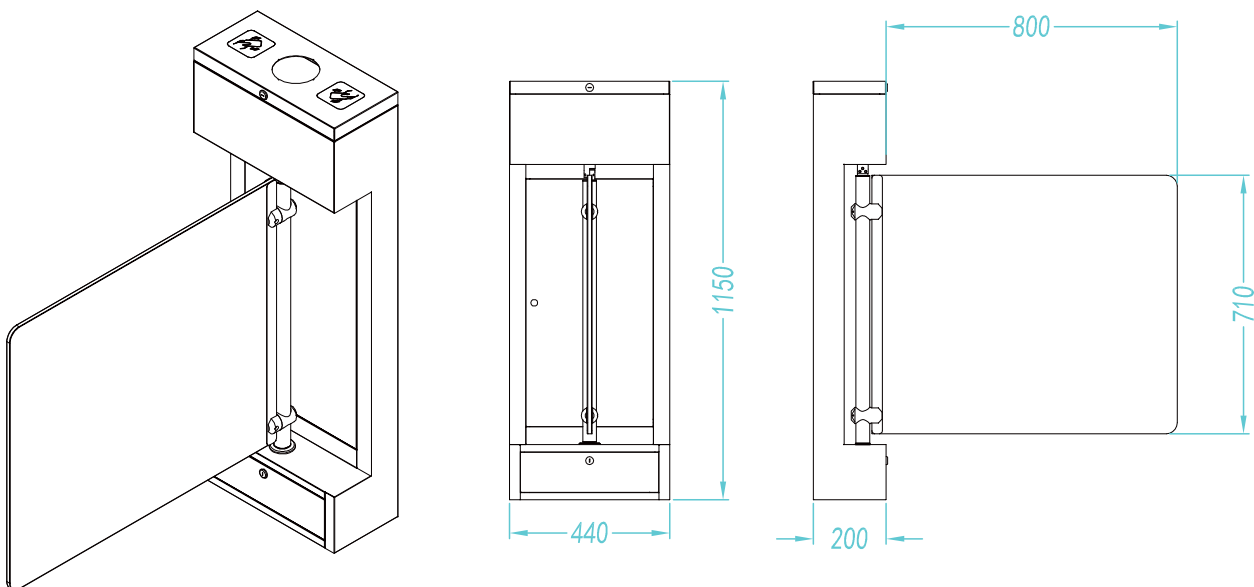

## VANTAGE INTEGRATED SECURITY SOLUTIONS LIMITED.

B3, Bredon House 321, Tenttenhall Road Tettenhall, Wolverhampton  
West Midlands, WV6 0JZ United Kingdom

Ph:+44-1902-793383, Email: sales@vantagesecurity.com

[www.vantagesecurity.com](http://www.vantagesecurity.com)

(AN ISO 9001 : 2008, ISO 14001:2004 CERTIFIED COMPANY)

