

PEOPLE ENTRANCE MANAGEMENT SYSTEM

V-PM4230SC/DC-SGT3 SINGLE/DOUBLE MACHINE CORE SWING GATE



FEATURES

Heavy-duty motorized-automatic swing gate

Single/dual core and Selectable operating modes supported - single direction, bi-direction, always free or always locked

Half height operation with standard passage width 550mm

LED status indicator & adjustable time out delay

Automatic reset of barrier gate after each passage

Integration support with any RFID/Biometric Reader through NO input

Fail safe function supported in case of emergency

Top quality AISI 304 grade SS construction with IP54 rating



LED Direction
Indicators



IP54



100%
Duty Cycle



Delay Time



Wired
Terminal

TECHNICAL SPECIFICATIONS

V-PM4230SC/DC-SGT3

Parameter	Specifications
Passage width	Standard 550mm; optional 900mm
Throughput rate	35-40 persons per minute
Opening & Closing Speed	0.5~ 0.8s
Passing Time	5s default (adjustable 0-25s)
Safety Sensors	4 pairs of infrared sensors for smooth passage traffic and protection of pedestrian
Passage Direction	Unidirectional/ bidirectional
Drive	Electro-magnetic DC motor drive
Power/Mechanism Failure	Fail safe status for either one or both directions be in free movement mode
Fire Alarm Integration	Supported to provide free passage for evacuation
Motor Power	30W (DC brushless)
Service Life	>5 million operation cycles
Communication Interface	Relay Input (NO/NC/COMM) Optional RS232/RS485
Operating Voltage	DC 24V
Power Supply Voltage	AC100~240 V
Power Consumption	55W
Working Temperature	-25°C~+70°C
Relative Humidity	≤90% no condensation
IP Rating	IP54 (IP56 optional)
Chassis Material	Top quality AISI 304 grade stainless steel (optional 316 grade)
Door Material	Acrylic flaps
Dimension	1200x185x980 mm
Net weight	30kg single core, 37kg double core
Certifications	CE, FCC, ROHS

*Exact products and specifications shown may vary by geographic region and are subject to change without notice. Product image & weights, measurements are approximate and may vary.

DIMENSIONS

Unit: mm

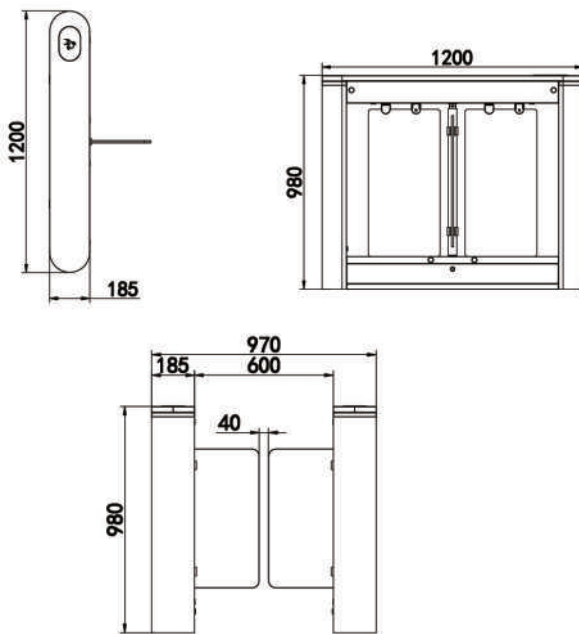

V-PM4230SC/DC-SGT3

Installation Diagram:

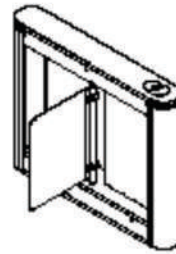
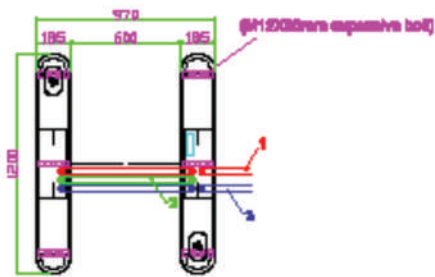
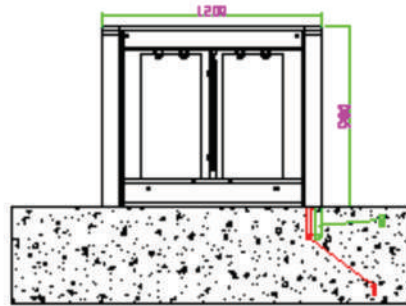
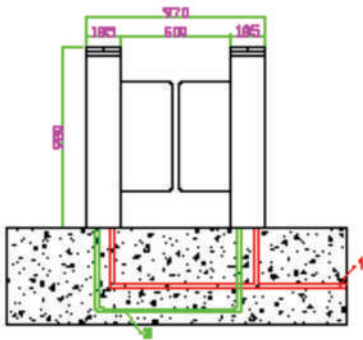

VANTAGE INTEGRATED SECURITY SOLUTIONS LIMITED.

B3, Bredon House 321, Tenttenhall Road Tettenhall, Wolverhampton
West Midlands, WV6 0JZ United Kingdom
Ph:+44-1902-793383, Email: sales@vantagesecurity.com

www.vantagesecurity.com

(AN ISO 9001 : 2008, ISO 14001:2004 CERTIFIED COMPANY)

