

PEOPLE ENTRANCE MANAGEMENT SYSTEM

V-PM4700SC/DC-SGT3 SINGLE/DOUBLE MACHINE CORE SWING GATE



FEATURES

- Heavy-duty motorized-automatic swing gate
- Single/dual core and selectable operating modes supported - single direction, bi-direction, always free or always locked
- Half height operation with passage width of <600mm
- LED status indicator & adjustable time out delay
- Automatic reset of barrier gate after each passage
- Integration support with any RFID/Biometric Reader through NO input
- Fail safe & fail lock function supported in case of emergency
- Top quality AISI 304 grade SS construction with IP54 rating

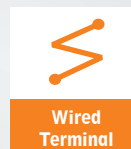
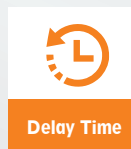

TECHNICAL SPECIFICATIONS

V-PM4700SC/DC-SGT3

Parameter	Specifications
Passage Width	600mm (standard), 900mm /1300mm (optional)
Throughput Rate	35-40 persons per minute
Opening & Closing Speed	0.5~ 0.8s
Passing Time	5s default (adjustable 0-25s)
Safety Sensors	14 pairs of infrared sensors for smooth passage traffic and protection of pedestrian
Passage Direction	Unidirectional/ bidirectional
Drive	Electro-mechanical DC motor drive
Power/Mechanism Failure	Fail safe or fail lock status for either one or both directions be in free movement mode (standard) or locks in the home position
Fire Alarm Integration	Supported to provide free passage for evacuation
Motor Power	55W (DC brushless)
Service Life	>10 million operation cycles
Communication Interface	Relay Input (NO/NC/COMM) Optional RS232/RS485
Operating Voltage	DC 24V
Power Supply Voltage	AC100~240 V
Power Consumption	45W
IP Rating	IP54 (IP56 optional)
Working Temperature	-25°C~+70°C
Relative Humidity	≤90% no condensation
Chassis Material	Top quality AISI 304 grade stainless steel (optional 316 grade)
Door Material	Acrylic
Dimension	1500x200x980mm (standard), 1700x200x980mm (optional)
Net weight	65kg single core, 80kg double core (standard), 70kg single core, 90kg double core (optional)
Certifications	CE, FCC, ROHS

*Exact products and specifications shown may vary by geographic region and are subject to change without notice. Product image & weights, measurements are approximate and may vary.

DIMENSIONS

Unit: mm

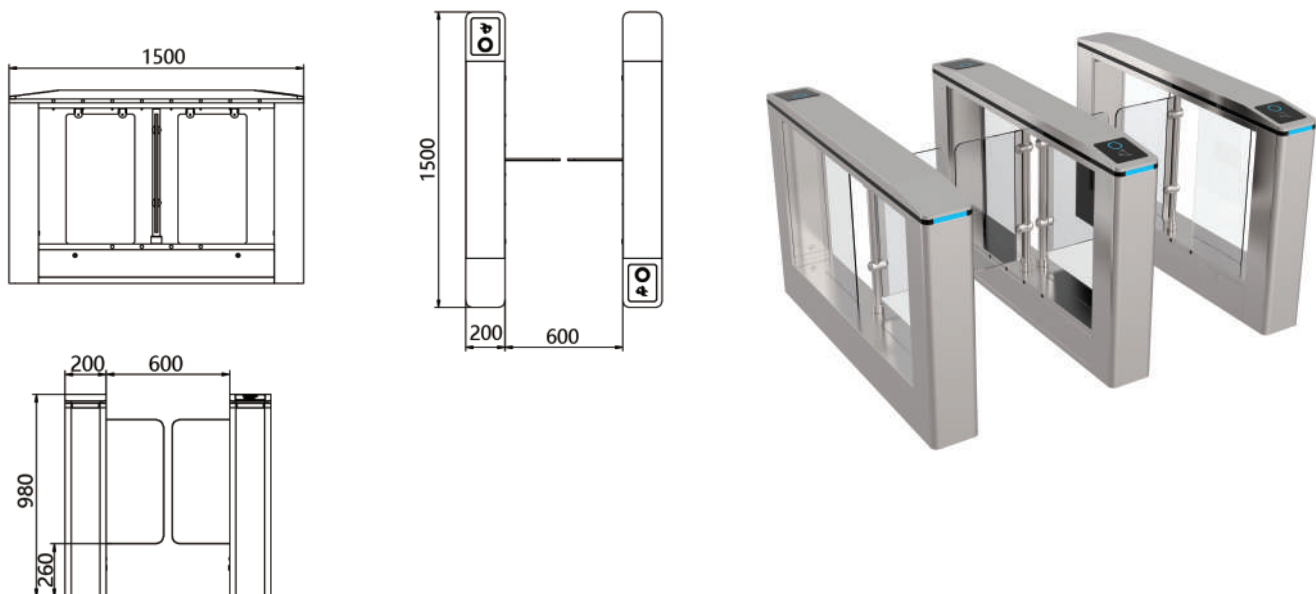

VANTAGE INTEGRATED SECURITY SOLUTIONS LIMITED.

B3, Bredon House 321, Tenttenhall Road Tettenhall, Wolverhampton

West Midlands, WV6 0JZ United Kingdom

Ph:+44-1902-793383, Email: sales@vantagesecurity.com

www.vantagesecurity.com

(AN ISO 9001 : 2008, ISO 14001:2004 CERTIFIED COMPANY)

