

# PEOPLE ENTRANCE MANAGEMENT SYSTEM

## V-PM5030SC/DC-SGT3 SINGLE/DOUBLE MACHINE CORE SWING GATE



### FEATURES

- Heavy-duty motorized-automatic swing gate
- Single/dual core and bi-directional operations supported
- Full height operation with passage width of 600/900mm
- LED status indicator & adjustable time out delay
- Automatic reset of barrier gate after each passage
- Integration support with any RFID/Biometric Reader through NO input
- Fail safe & fail lock function supported in case of emergency
- Top quality AISI 304 grade SS construction with IP44 rating



LED Direction  
Indicators

INGRESS  
PROTECTION  
RATING

**IP44**



100%  
Duty Cycle



Delay Time



Wired  
Terminal

## TECHNICAL SPECIFICATIONS

# V-PM5030SC/DC-SGT3

Parameter	Specifications
Passage width	Standard 600mm; optional 900mm
Throughput rate	35 persons per minute
Safety Sensors	12 pairs of infrared sensors for smooth passage traffic and protection of pedestrian
Passage Direction	Unidirectional/ bidirectional
Drive	Brushless Servo motor
Fire Alarm Integration	Supported to provide free passage for evacuation
Communication Interface	Relay Input (NO/NC/COM)
Frequency	50-60Hz
Service Life	>5 million operation cycles
Motor Voltage	DC 24V
Input Voltage	AC100~240 V
Power Consumption	100W
Working Temperature	-25°C~+70°C
Relative Humidity	≤90% no condensation
IP Rating	IP44
Chassis Material	Top quality AISI 304 grade SS construction and 12mm white marble (top cover material)
Door Material	Tempered glass
Dimension	1500x150x980mm
Net weight	100kg
Certifications	CE, FCC, ROHS

\*Exact products and specifications shown may vary by geographic region and are subject to change without notice. Product image & weights, measurements are approximate and may vary.

## DIMENSIONS

Unit: mm

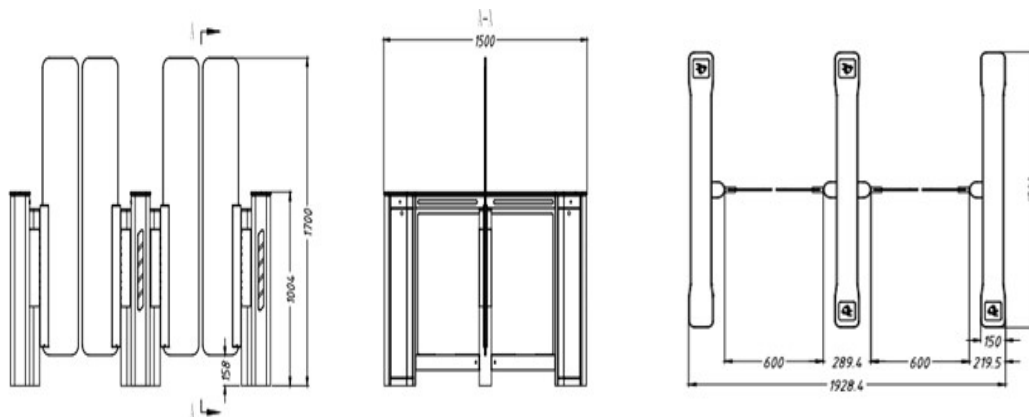

## VANTAGE INTEGRATED SECURITY SOLUTIONS LIMITED.

B3, Bredon House 321, Tenttenhall Road Tettenhall, Wolverhampton

West Midlands, WV6 0JZ United Kingdom

Ph: +44-1902-793383, Email: sales@vantagesecurity.com

[www.vantagesecurity.com](http://www.vantagesecurity.com)

(AN ISO 9001 : 2008, ISO 14001:2004 CERTIFIED COMPANY)

