

PEOPLE ENTRANCE MANAGEMENT SYSTEM

VP-PM5020SC/DC-SGT3 SINGLE / DOUBLE CORE SLIDING GATE



FEATURES

- Heavy-duty motorized-automatic slide gate
- Single/dual machine core with bi-directional operating modes supported
- Half height operation with standard passage width 600mm
- LED status indicator & adjustable time out delay
- Automatic reset of barrier gate after each passage
- Integration support with any RFID/Biometric Reader through NO input
- Fail safe function supported in case of emergency
- Top quality AISI 304 grade SS construction

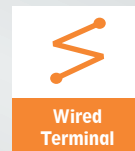
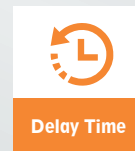

TECHNICAL SPECIFICATIONS

VP-PM5020SC/DC-SGT3

Parameter	Specifications
Passage Width	Standard 600mm; optional 900 mm
Throughput Rate	35-40 persons per minute
Opening & Closing Speed	0.5 ~ 0.8s
Passing Time	5s default (adjustable 0-25s)
Safety Sensors	9 pairs of infrared sensors for smooth passage traffic and protection of pedestrian
Passage Direction	Unidirectional/ bidirectional
Drive	Electro-mechanical DC motor drive
Power/Mechanism Failure	Fail safe status for either one or both directions be in free movement mode
Fire Alarm Integration	Supported to provide free passage for evacuation
Motor Power	100W (DC brushless Servo motor)
Service Life	>10 million operation cycles
Communication Interface	Relay Input (NO/NC/COMM) Optional RS232/RS485
Operating Voltage	DC 24V
Power Supply Voltage	AC100~240 V
Max. Power Consumption	150W
IP Rating	IP44
Working Temperature	-25°C~+70°C
Relative Humidity	≤90% no condensation
Chassis Material	Top quality AISI 304 grade stainless steel (optional 316 grade)
Door Material	Tempered glass flaps
Dimension	1500x300x980mm
Net weight	140kg single core, 180kg double core
Certifications	CE, FCC, ROHS

*Exact products and specifications shown may vary by geographic region and are subject to change without notice. Product image & weights, measurements are approximate and may vary.

DIMENSIONS

Unit: mm

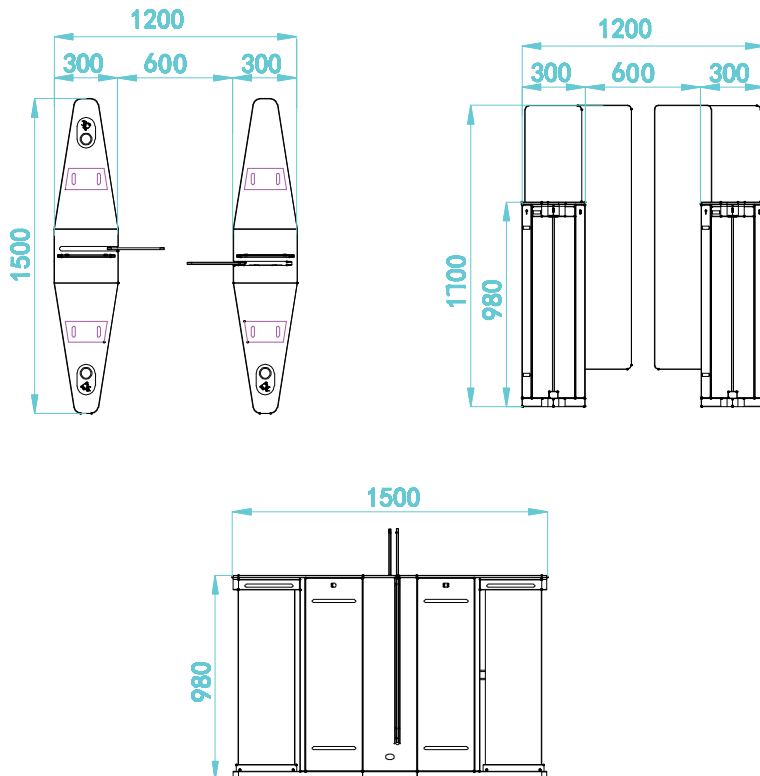

INSTALLATION DIAGRAM

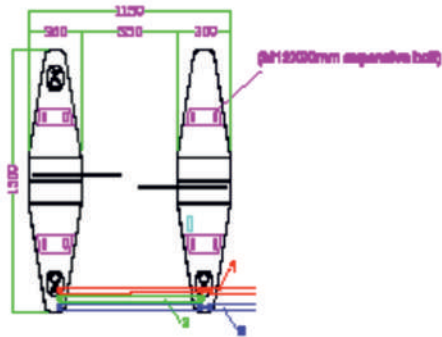
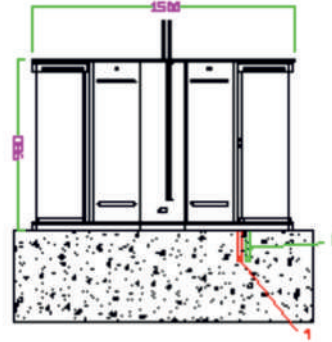
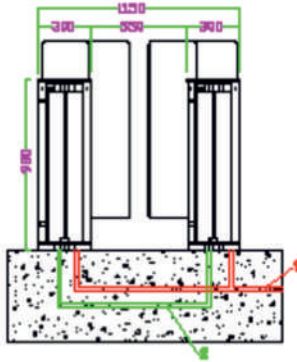

VANTAGE INTEGRATED SECURITY SOLUTIONS LIMITED.

B3, Bredon House 321, Tenttenhall Road Tettenhall, Wolverhampton

West Midlands, WV6 0JZ United Kingdom

Ph:+44-1902-793383, Email: sales@vantagesecurity.com

www.vantagesecurity.com

(AN ISO 9001 : 2008, ISO 14001:2004 CERTIFIED COMPANY)

