

HIGH DEFINITION 5MP ANALOG BULLET CAMERA

VV-AC5M80B-M12ZT1 IR NIGHT VISION MOTORIZED CAMERA



FEATURES

5 Megapixel HD resolution (2560x1936 pixels)

1/2.7" Progressive Scan CMOS sensor

AHD / TVI / CVI / CVBS camera supported

Inbuilt IR LEDs for 50 mtr IR range

High performance IR Cut mechanical filter for True Day & night vision

Up to 1500 TVL resolution

High performance IR with intensity control

IP67 Weather proof outdoor enclosure

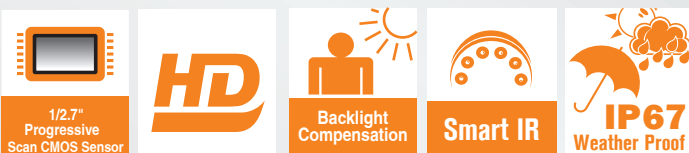

TECHNICAL SPECIFICATIONS

VV-AC5M80B-M12ZT1

Camera	Image sensor	1/2.7" Progressive Scan CMOS Sensor
	Signal System	PAL/NTSC
	Effective Pixels	2560 (H) x 1936 (V)
	Frequency	50 Hz (PAL) / 60 Hz (NTSC)
	Image Resolution	5 Megapixel
	Minimum Illumination	Color : 0.01 lux@F1.2, AGC ON; B/W : 0 lux with IR
	Signal to Noise	≥52dB
	Shutter Time	Auto
	Gain Control	Auto
	White Balance	Auto / Manual
	Angle Adjustment	Pan: 0°~360°; Tilt: 0°~80°; Rotation: 0°~360°
Lens	Lens Type	2.8~12mm motorized lens
	Lens Mount	D14
Day/Night Functionality	Day & Night	True Day & Night
	IR Cut	High performance Mechanical IR Cut Filter with auto switch
	IR Source	High performance IR LEDs with intensity control
	IR Range	Up to 50 Mtrs
Operational Features	Wide Dynamic Range (WDR)	Digital WDR
	Smart IR	Supported
	Frame Rate	5MP@20fps
	OSD Menu	Supported
	LSC	Supported
	BLC	Supported
	HLC	Supported
	Image Setting	Supported
	Mirror	Supported
Defect Correction	Supported	
Interface	Video Output	AHD / TVI /CVI/CVBS Video output
	Power Input	Standard DC Jack
Electrical	Power Requirement (± 10%)	DC 12V (± 15%)
	Power Consumption	<6 W with IR on
Environmental	Enclosure	IP67 Weather proof outdoor enclosure
	Mounting bracket	Integrated mounting bracket with cable management
	Operating Temperature	-30°C to + 50°C
	Operating Humidity	90% or less (non-condensing)
Mechanical	Color	White
	Dimensions	217.7 x 80.5 x 80.5mm
	Weight	Approx. 0.57KG
Certification	Certification	CE, FCC, RoHS

*Exact products and specifications shown may vary by geographic region and are subject to change without notice. Weights and measurements are approximate and may vary.

TECHNICAL SPECIFICATIONS

VV-AC5M80B-M12ZT1

DIMENSIONS

Unit: mm

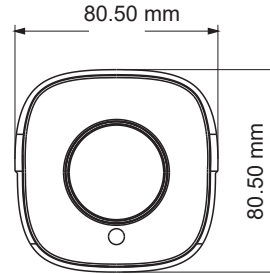
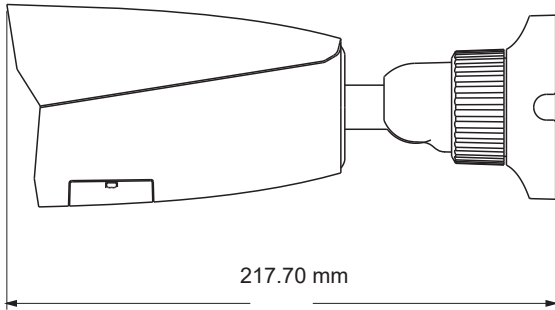

VANTAGE INTEGRATED SECURITY SOLUTIONS LIMITED

B3, Bredon House 321, Tenttenhall Road Tettenhall, Wolverhampton

West Midlands, WV6 0JZ United Kingdom

Ph:+44-1902793383, Email: sales@vantagesecurity.com

www.vantagesecurity.com

(AN ISO 9001 : 2008, ISO14001 : 2004 CERTIFIED COMPANY)

